

PENNS TWO ARRIVAL

NE-2, 12 SEP 2019 to 10 OCT 2019

NEW YORK APP CON
127.6 379.9
NEWARK D-ATIS
115.7 134.825

WILLIAMSPORT
114.4 FQM
Chan 91
N41°20.31'-W76°46.49'
L-30, H-10-12

WILKES-BARRE
111.6 LVZ
Chan 53
N41°16.37'-W75°41.37'
L-30-33-34, H-10-12

STILLWATER
109.6 STW
Chan 33

BROADWAY
114.2 BWZ
Chan 89

PENNS
N40°52.84'
W75°06.57'

SWEET
N40°49.70'
W74°55.46'

RACKI
N41°00.73'
W75°34.62'

HAYED
N41°08.64'
W76°03.21'

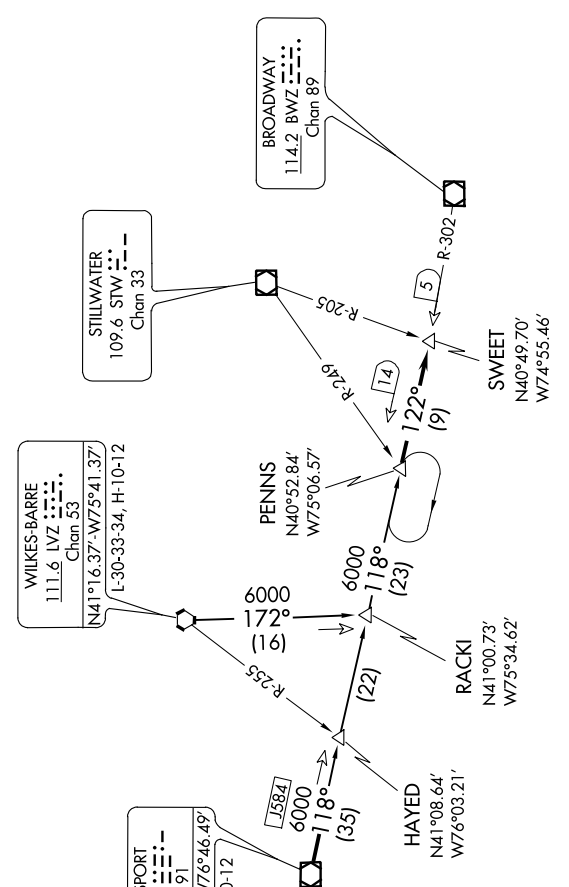

ARRIVAL ROUTE DESCRIPTION

WILKES-BARRE TRANSITION (LVZ.PENNS2): From over LVZ
 VORTAC via R-172 to RACKI INT, then via FQM R-118 to
 PENNS INT. Thence
 WILLIAMSPORT TRANSITION (FQM.PENNS2): From over FQM
 VOR/DME via FQM R-118 to PENNS INT. Thence

. . . . From over PENNS INT via BWZ VOR/DME R-302 to SWEET
 INT. Expect radar vectors to final approach course.

NOTE: This STAR is applicable to non-jet aircraft
 filed less than 250K landing Newark Liberty
 Intl airport.

NOTE: Chart not to scale.

NE-2, 12 SEP 2019 to 10 OCT 2019