

LOC/DME I-AKR <b>110.9</b> Chan <b>46</b>	APP CRS <b>249°</b>	Rwy Idg TDZE Apt Elev	<b>6077</b> <b>1059</b> <b>1068</b>
---	------------------------	-----------------------------	---

**LOC RWY 25**  
AKRON FULTON INTL (AKR)

ADF or DME or RADAR required for procedure entry.

Rwy 25 helicopter visibility reduction below 1 SM NA.

MISSED APPROACH: Climb to 3100 on heading 249° and BSV VOR/DME R-322 to RITZS INT/BSV 21.2 DME and hold.

ASOS <b>126.825</b>	CLEVELAND APP CON * <b>118.6 371.875</b>	CLNC DEL <b>121.6</b>	UNICOM <b>123.075</b> (CTAF) <b>0</b>
------------------------	---	--------------------------	--

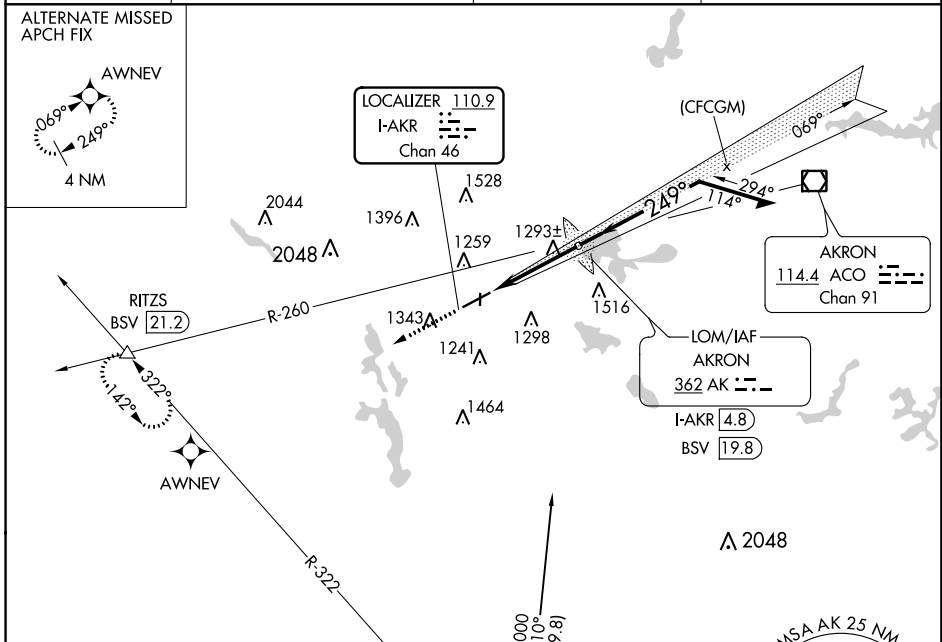

ELEV 1068	TDZE 1059
-----------	-----------

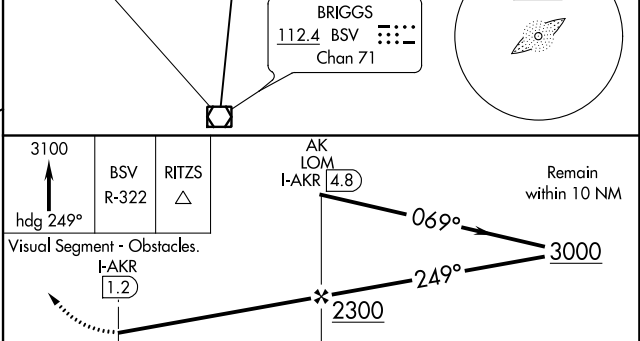
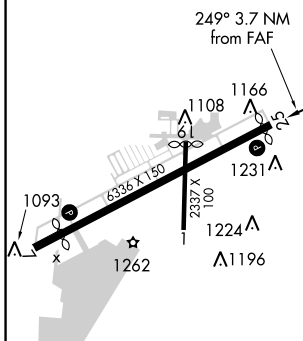

CATEGORY	A	B	C	D
S-LOC 25	1560-1	501 (500-1)	1560-1 3/8	501 (500-1 3/8)
<b>CIRCLING</b>	1600-1 532 (600-1)	1680-1 612 (700-1)	1800-2 732 (800-2)	1840-2 1/2 772 (800-2 1/2)

EC-2, 10 OCT 2019 to 07 NOV 2019

EC-2, 10 OCT 2019 to 07 NOV 2019