

WAAS CH <b>86501</b> <b>W18A</b>	APP CRS <b>185°</b>	Rwy Idg <b>6500</b> TDZE <b>740</b> Apt Elev <b>764</b>
--	------------------------	---

# RNAV (GPS) RWY 18

HUNTSVILLE EXECUTIVE TOM SHARP JR FIELD (MDQ)

RNP APCH.	MISSED APPROACH: Climb to 1500 then climbing left turn to 3400 direct EROVE and hold.
<p>▼ Rwy 18 helicopter visibility reduction below ¾ SM NA. ▲ For uncompensated Baro-VNAV systems, procedure NA below -16°C or above 54°C.</p>	

AWOS-3PT <b>120.0</b>	HUNTSVILLE APP CON * <b>125.6 354.1</b>	GCO <b>121.725</b>	UNICOM <b>123.0 (CTAF) 0</b>
--------------------------	--	-----------------------	---------------------------------

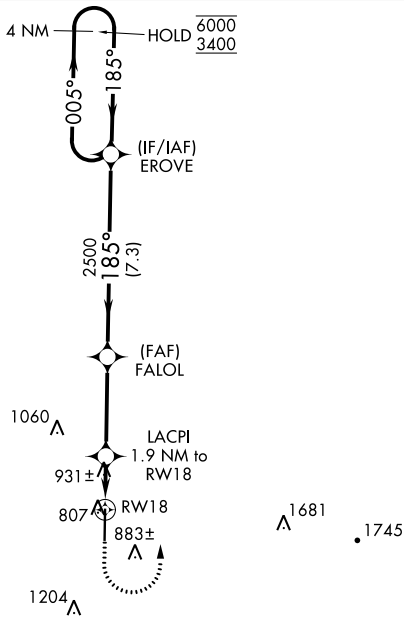
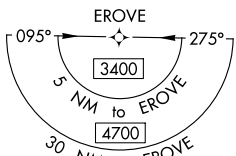
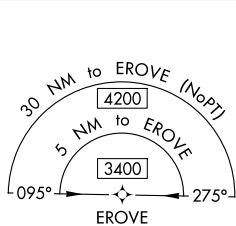

ELEV <b>764</b>	TDZE <b>740</b>
-----------------	-----------------

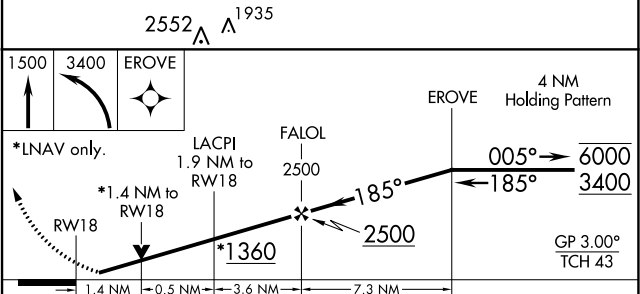
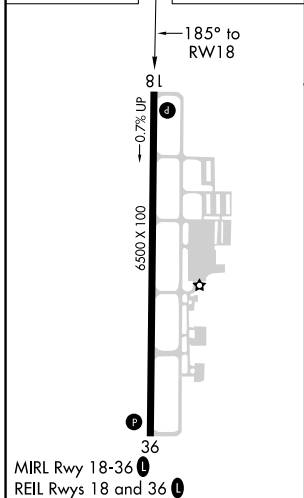

CATEGORY	A	B	C	D
LPV DA		940-¾	200 (200-¾)	
LNAV/VNAV DA		1250-1¾	510 (500-1¾)	
LNAV MDA	1200-1	460 (500-1)	1200-1¾	460 (500-1¾)
CIRCLING	1260-1	496 (500-1)	1560-2¼ 796 (800-2¼)	2000-3 1236 (1300-3)

SE-4, 05 NOV 2020 to 03 DEC 2020

SE-4, 05 NOV 2020 to 03 DEC 2020