

NDB VOF	APP CRS	Rwy Idg	<b>5500</b>
<b>370</b>	<b>275°</b>	TDZE	<b>809</b>
		Apt Elev	<b>809</b>

# NDB RWY 28

COVINGTON MUNI (CVC)

<p><b>▼</b> Helicopter visibility reduction below 3/4 SM NA. When local altimeter setting not received, use Lawrenceville altimeter setting and increase all MDA 100 feet and S-28 Cats C/D visibilities 3/8 mile and Circling Cat C visibility 1/4 mile.</p> <p><b>▲ NA</b></p>	<p>MALSRL</p>	<p>MISSED APPROACH: Climb to 2000 then climbing left turn to 2500 direct VOF NDB and hold.</p>
--	---------------	--

AWOS-3 <b>118.725</b>	ATLANTA APP CON <b>128.575 343.675</b>	CLNC DEL <b>119.875</b>	UNICOM <b>123.0 (CTAF) 0</b>
--------------------------	---	----------------------------	---------------------------------

Λ 2049

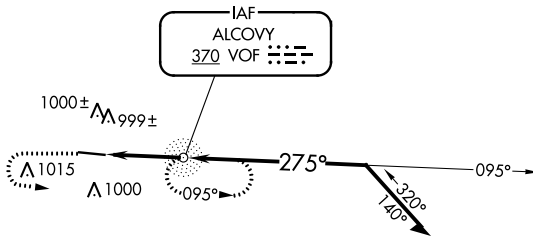

Λ 1208

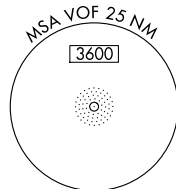
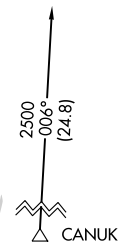

ELEV 809	TDZE 809
----------	----------

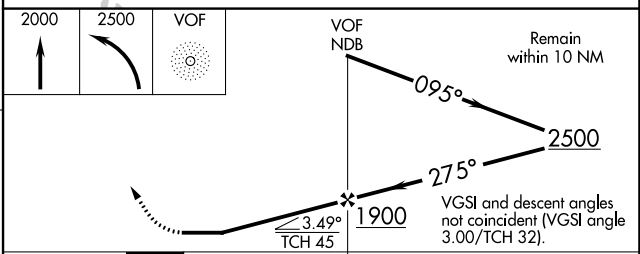
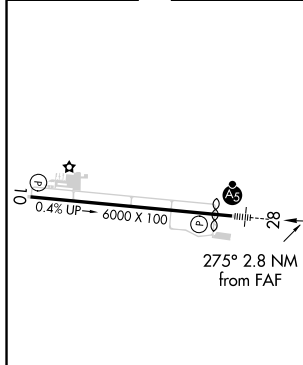

MIRL Rwy 10-28 0	FAF to MAP 2.8 NM				
Knots	60	90	120	150	180
Min:Sec	2:48	1:52	1:24	1:07	0:56
CATEGORY	A	B	C	D	
S-28	1300-1	491 (500-1)	1300-1 3/8	491 (500-1 3/8)	
CIRCLING	1300-1 491 (500-1)	1360-1 551 (600-1)	1360-1 1/2 551 (600-1 1/2)	1360-2 551 (600-2)	

SE-4, 25 MAR 2021 to 22 APR 2021

SE-4, 25 MAR 2021 to 22 APR 2021