

LOC/DME I-JAV 110.5 Chan 42	APP CRS 093°	Rwy Idg TDZE Apt Elev 7709 660 680
--	------------------------	--

ILS or LOC RWY 9R

CHICAGO O'HARE INTL (ORD)

From GIBNS: RNAV 1-GPS required. RADAR or DME required.
Aircraft not GPS equipped: RADAR required for procedure entry.

Simultaneous approach authorized.
For inop ALS, increase S-LOC 9R Cat C/D visibility to 1 1/2 SM.

MALSR  MISSED APPROACH: Climb to 4000 on OBK VOR/DME R-124 to GRABL INT/OBK 26.9 DME/RADAR and hold.

CHICAGO APP CON 119.0 292.125	O'HARE TOWERS 128.15 348.0 (Rwy 9L/27R) 126.9 348.0 (110R/28L) 132.7 348.0 (CENTER)	124.125 (TWR NORTH) 118.05 (TWR SOUTH) 226.675 (ALL TWRs)	GND CON (TWR CENTER) 121.75 (OBND) 121.9 (IBND)	CLNC DEL 121.6
---	---	--	---	--------------------------

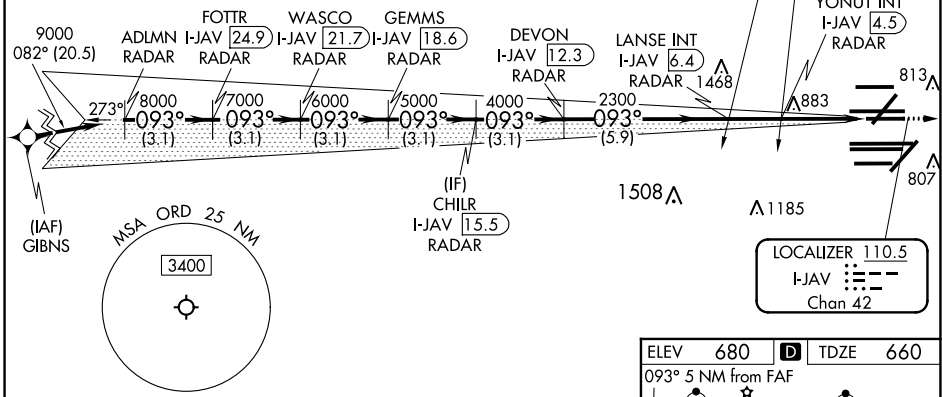
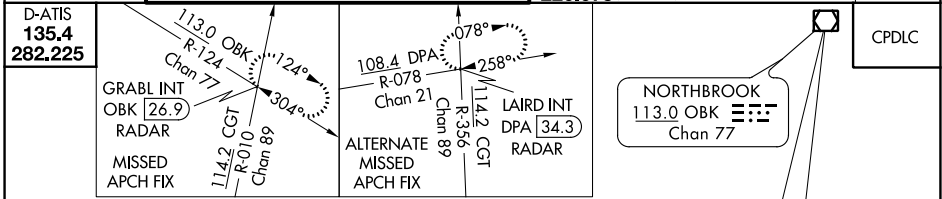

VGS and ILS glidepath not coincident (VGS Angle 3.00/TCH 74).		4000	OBK R-124	GRABL INT
ADLMN RADAR	FOTTR I-JAV 24.9 RADAR	WASCO I-JAV 21.7 RADAR	CHILR I-JAV 15.5 RADAR	LANSE INT I-JAV 6.4 RADAR
9000	8000	7000	6000	5000
GS 3.00° TCH 57	3.1 NM	3.1 NM	3.1 NM	3.1 NM
			5.9 NM	1.9 NM
				1.8 1.3
CATEGORY	A	B	C	D
S-ILS 9R	860/18		200 (200-1/2)	
S-LOC 9R	1160/24		500 (500-1/2)	

ELEV 680	TDZE 660
093° 5 NM from FAF	
HIRL all Rwys	
TDZ/CL all Rwys except 4L	
FAF to MAP 5 NM	
Knots	60 90 120 150 180
Min:Sec	5:00 3:20 2:30 2:00 1:40

EC-3, 22 APR 2021 to 20 MAY 2021

EC-3, 22 APR 2021 to 20 MAY 2021