

LOC/DME I-JAV 110.5 Chan 42	APP CRS 093°	Rwy ldg 7709 TDZE 660 Apt Elev 680
---	------------------------	---

ILS or LOC RWY 9R

CHICAGO O'HARE INTL (ORD)

From GIBNS: RNAV 1-GPS required. RADAR or DME required.
Aircraft not GPS equipped: RADAR required for procedure entry.

Simultaneous approach authorized.
For inop ALS, increase S-LOC 9R Cat C/D visibility to 1 1/2 SM.

MALSR MISSED APPROACH: Climb to 4000 on OBK VOR/DME R-124 to GRABL INT/OBK 26.9 DME/RADAR and hold.

CHICAGO APP CON 119.0 292.125	O'HARE TOWERS 128.15 348.0 (Rwy 9L/27R) 126.9 348.0 (10R/28L) 132.7 348.0 (CENTER)	124.125 (TWR NORTH) 118.05 (TWR SOUTH) 226.675 (ALL TWRs)	GND CON (TWR CENTER) 121.75 (OBND) 121.9 (IBND)	CLNC DEL 121.6
---	--	--	---	--------------------------

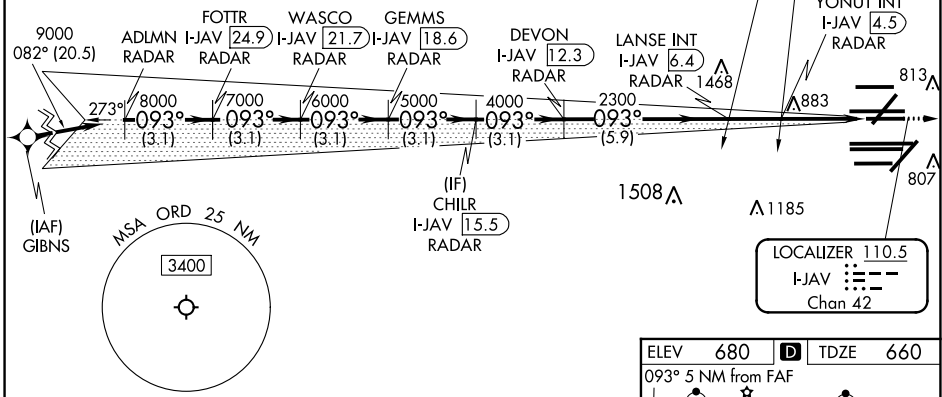
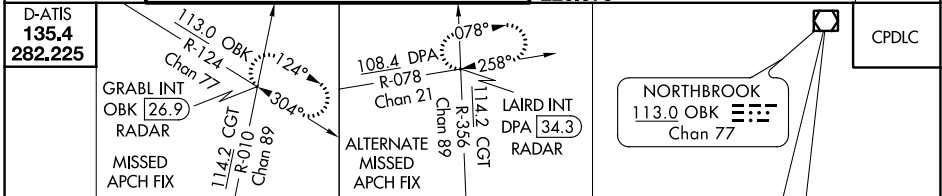

VGSI and ILS glidepath not coincident (VGSI Angle 3.00/TCH 74).

CATEGORY	A	B	C	D
S-ILS 9R	860/18		200 (200-1/2)	
S-LOC 9R	1160/24		500 (500-1/2)	
			1160/50	
			500 (500-1)	

HIRL all Rwws
TDZ/CL all Rwws except 4L

FAF to MAP 5 NM					
Knots	60	90	120	150	180
Min:Sec	5:00	3:20	2:30	2:00	1:40

EC-3, 15 JUL 2021 to 12 AUG 2021

EC-3, 15 JUL 2021 to 12 AUG 2021