

APP CRS	Rwy Idg	<b>12000</b>
<b>082°</b>	TDZE	<b>5352</b>
	Apt Elev	<b>5434</b>

# RNAV (RNP) Z RWY 7

DENVER INTL (DEN)

RNP AR APCH.

▼ Simultaneous approach authorized. For uncompensated Baro-VNAV systems, procedure NA below -23°C or above 54°C. For inop ALS, increase RNP 0.15 all Cats visibility to RVR 4000, and increase RNP 0.30 all Cats visibility to RVR 6000.

MALSR



MISSED APPROACH: Climb to 5900 then climbing right turn to 10000 direct CIDMU and track 081° to LIMEX and hold.

D-ATIS	DENVER APP CON	DENVER TOWER	GND CON	CLNC DEL	CPDLC
ARR <b>125.6 379.9</b>	<b>119.3 307.3 120.35 379.3</b> (NORTH) (SOUTH)	<b>128.75 273.55</b>	<b>127.5 379.175</b>	<b>118.75</b>	
DEP <b>134.025</b>					

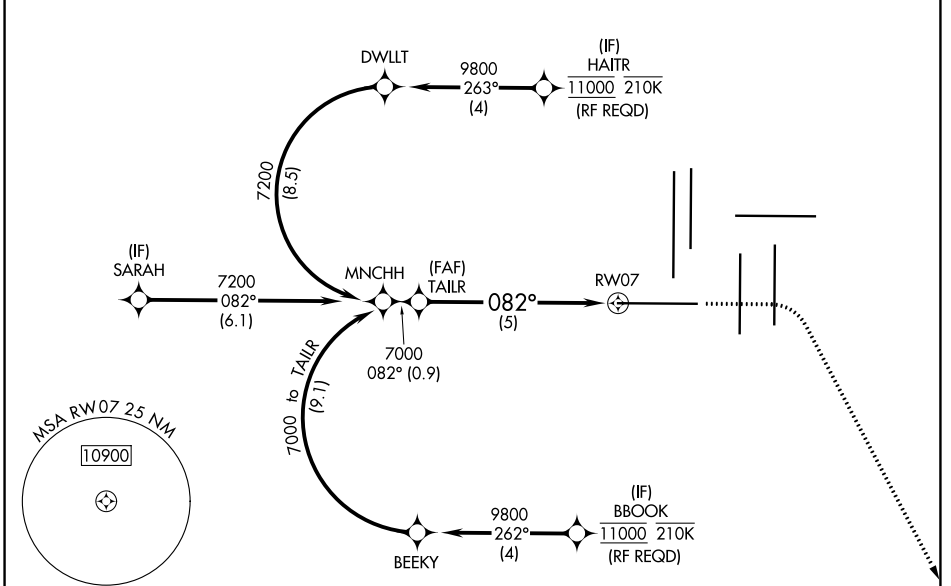

SW-1, 09 SEP 2021 to 07 OCT 2021

SW-1, 09 SEP 2021 to 07 OCT 2021

ELEV 5434	<b>D</b>	TDZE 5352
-----------	----------	-----------

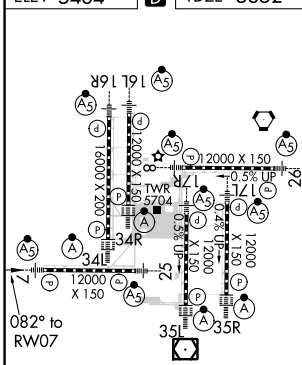

HIRL all Rwys  
TDZ/CL Rwys 7, 16L, 16R, 17R,  
26, 34L, 34R, 35L, 35R

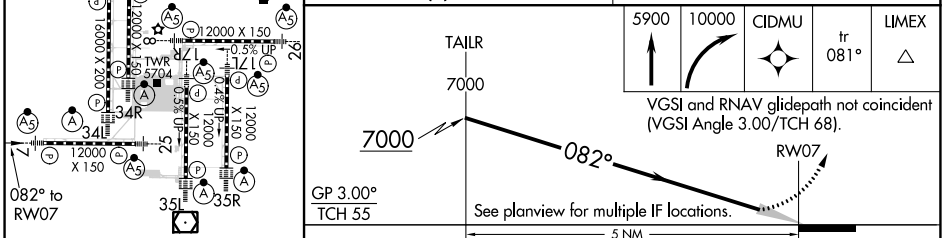
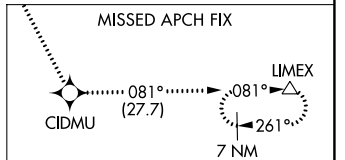

CATEGORY	A	B	C	D
RNP 0.15 DA		5602/24	250 (200-½)	
RNP 0.30 DA		5753/40	401 (400-¾)	

**AUTHORIZATION REQUIRED**