

WAAS CH <b>86438</b> <b>W32A</b>	APP CRS <b>324°</b>	Rwy Idg TDZE Apt Elev	<b>5731</b> <b>4546</b> <b>4595</b>
--	------------------------	-----------------------------	---

# RNAV (GPS) RWY 32

FORT MORGAN MUNI (FMM)

**⚠** DME/DME RNP-0.3 NA. When local altimeter setting not received, use Akron altimeter setting: increase all DA to 4879 feet and all visibilities ½ mile; increase all MDA 100 feet and all Cat C and D visibilities ¼ mile. Night landing: Rwy 8, 17, 26, 32, 35 NA. Helicopter visibility reduction below 1 SM NA.

**MISSED APPROACH:**  
Climb to 7400 direct ECUDI and hold.

AWOS-3PT <b>132.95</b>	DENVER CENTER <b>118.475 225.4</b>	UNICOM <b>123.05 (CTAF) 0</b>
---------------------------	---------------------------------------	----------------------------------

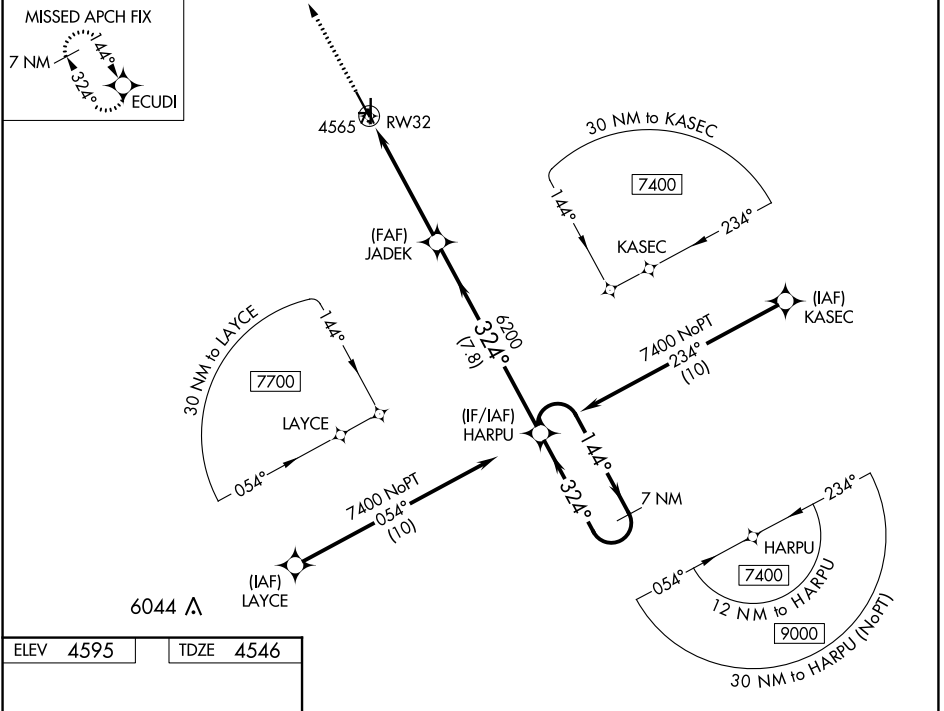

ELEV	4595	TDZE	4546
------	------	------	------

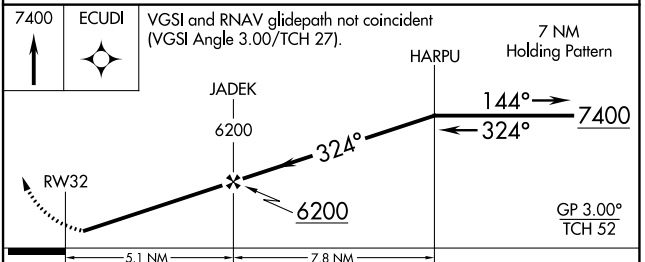
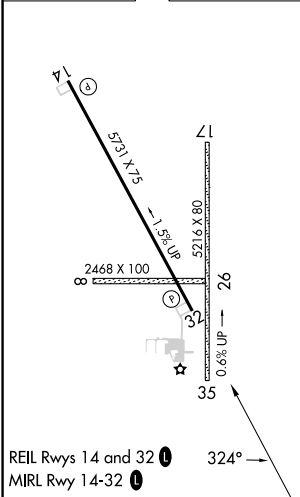

CATEGORY	A	B	C	D
LPV DA		4796-1	250 (300-1)	
LNAV/VNAV DA		4796-1	250 (300-1)	
LNAV MDA		4820-1	274 (300-1)	
<b>C</b> CIRCLING	5040-1 445 (500-1)	5080-1 485 (500-1)	5120-1½ 525 (600-1½)	5340-2½ 745 (800-2½)