

ALTUS, OKLAHOMA

RNAV (GPS) Z RWY 18R

APCH CRS 175°	Rwy Idg 13,440
	TDZE 1378
	Arpt Elev 1382

AL-482 (USAF)

ALTUS AFB (KLTS)

RNP APCH. DME/DME RNP-0.3 NA	SALS	MISSED APPROACH: Climb to 4000 direct OKKIE and hold.
<p>▼ * When ALS inop increase RVR to 45, vis to 7/8 mile. ** When ALS inop, increase CAT AB RVR to 55, vis to 1 mile; CAT CDE RVR to 60, vis to 1 1/8 miles.</p>	(A2)	

ATIS* 109.8 273.5	FORT WORTH CENTER 133.5 350.35	APP CON 125.1 353.7	TOWER* 119.65 254.4	GND CON 121.85 275.8	CLNC DEL 120.65 284.7
----------------------	-----------------------------------	------------------------	------------------------	-------------------------	--------------------------

*** Circling NA W of Rwy 18R-36L.

For uncompensated Baro-VNAV systems, procedure NA below -17°C or above 54°C (130°F).

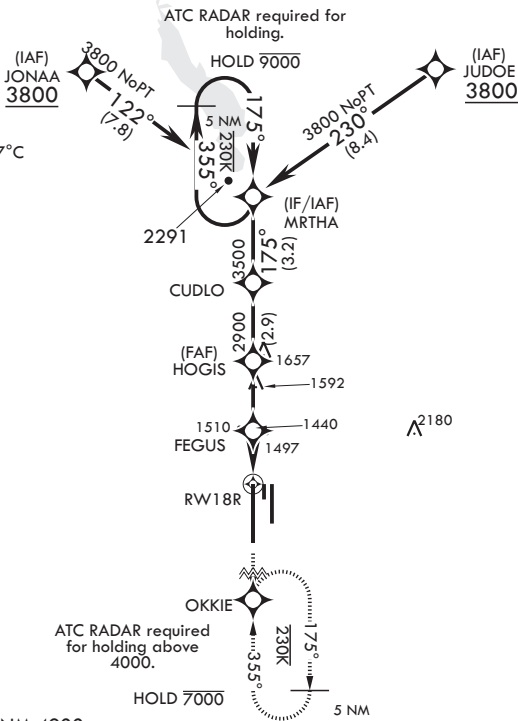

EMERG SAFE ALT 100 NM 4900

MRTHA	355°	175°	3500	HOGIS	FEGUS	2040	2.6 NM	2 NM	4000	OKKIE	ELEV 1382	175° to RW18R	TDZE 1378
GP 3.00° †	TCH 53			2900	0.9 NM to RW18R							176°	
												0.4% DOWN	
												0.3% DOWN	
CATEGORY	A	B	C	D	E								
LNAV/VNAV DA*	1660/40		282		(300-¾)								
LNAV MDA**	1760/40 382 (400-¾)		1760/45		382 (400-¾)								
Ⓢ CIRCLING***	1780-1 398 (400-1)	1840-1 458 (500-1)	1880-1½ 498 (500-1½)	2080-2¼ 698 (700-2¼)	2180-2¾ 798 (800-2¾)								

ALTUS, OKLAHOMA

34°40'N - 99°16'W

ALTUS AFB (KLTS)

Amdt 3 14JUL22

RNAV (GPS) Z RWY 18R

SC-1, 13 JUN 2024 to 11 JUL 2024

SC-1, 13 JUN 2024 to 11 JUL 2024