

APP CRS	Rwy Idg	4199
120°	TDZE	707
	Apt Elev	707

RNAV (GPS) RWY 12

DEFIANCE MEML (DFI)

RNP APCH.	MISSED APPROACH: Climb to 3000 direct JUTLI and on track 117° to KLOEE and hold.
<p>▼ Circling Rwy 30 NA at night. Rwy 12 helicopter visibility reduction below 3/4 SM NA.</p> <p>▲</p>	

ASOS 121.425	TOLEDO APP CON 134.35 307.0	UNICOM 122.7 (CTAF)
------------------------	---------------------------------------	-------------------------------

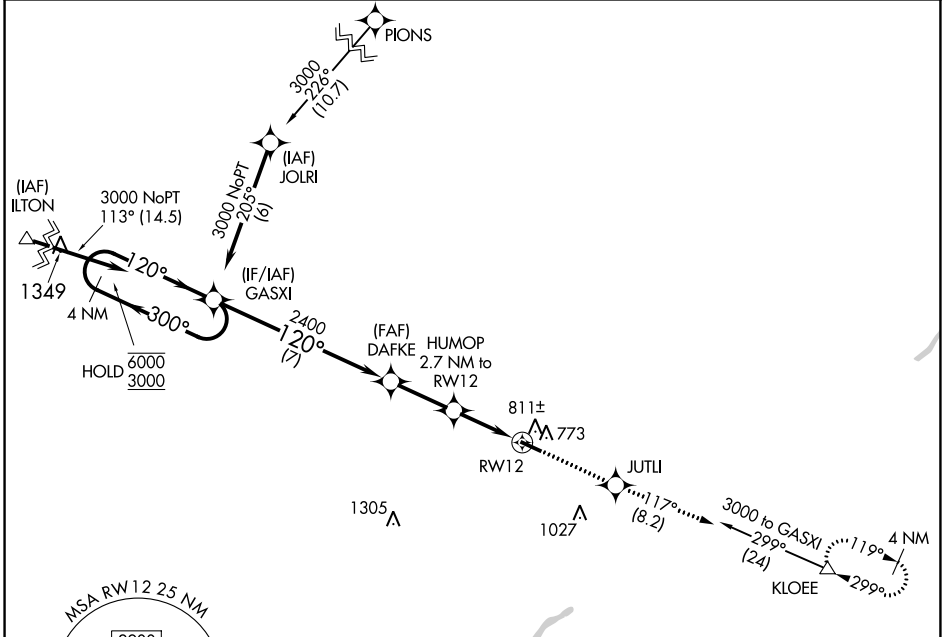

EC-2, 13 JUN 2024 to 11 JUL 2024

EC-2, 13 JUN 2024 to 11 JUL 2024

ELEV	707	TDZE	707
------	-----	------	-----

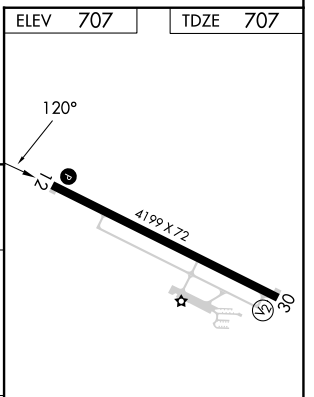
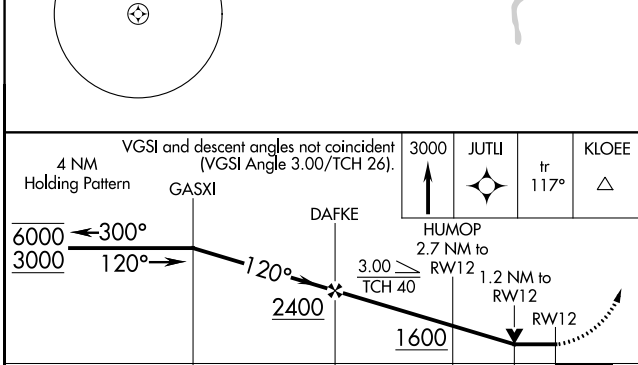

CATEGORY	A	B	C	D
LNVA MDA	1100-1	393 (400-1)	1100-1 1/8	393 (400-1 1/8)
C CIRCLING	1140-1 433 (500-1)	1160-1 453 (500-1)	1380-2 673 (700-2)	1380-2 1/4 673 (700-2 1/4)

REIL Rwy 12 and 30 **①**
MIRL Rwy 12-30 **②**