

WAAS CH 90135 W28A	APP CRS 276°	Rwy Idg TDZE Apt Elev	4400 1004 1004
--	------------------------	-----------------------------	---

RNAV (GPS) RWY 28

KENDALLVILLE MUNI (C62)

RNP APCH.

▼ Baro-VNAV NA when using Fort Wayne altimeter setting. For uncompensated Baro-VNAV systems, LNAV/VNAV NA below -16°C (4°F) or above 54°C (130°F). Rwy 28 helicopter visibility reduction below 1 SM NA. Straight-in Rwy 28 NA at night, Circling Rwy 28 NA at night. When local altimeter setting not received, use Fort Wayne altimeter setting and increase all DAs 96 feet and all MDAs 100 feet; increase LPV all Cats visibility 3/8 mile and LNAV/VNAV all Cats visibility 1/4 mile.

MISSED APPROACH: Climb to 3000 direct HIATT and on track 286° to BAGEL and hold.

AWOS-3P 119.925	FORT WAYNE APP CON 127.2 284.6	UNICOM 122.8 (CTAF) 1
---------------------------	--	---------------------------------

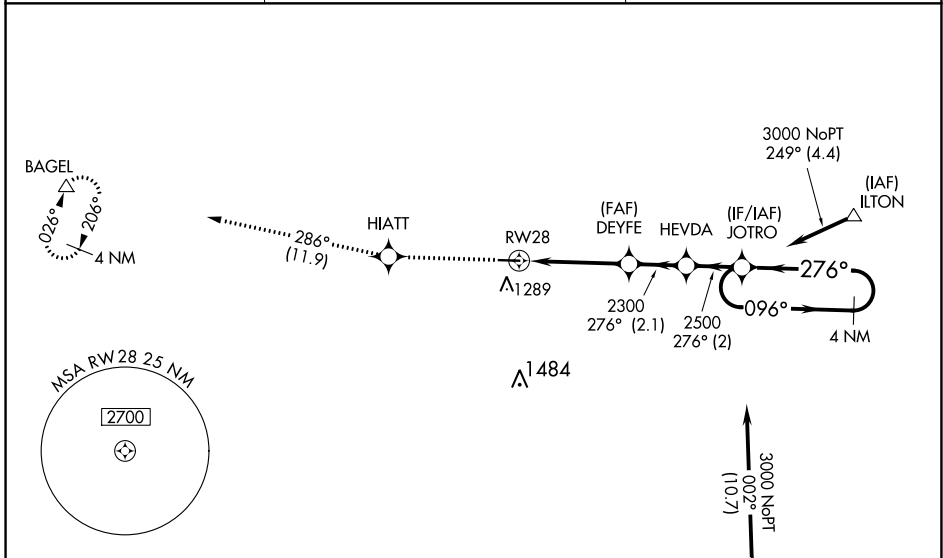

ELEV 1004	TDZE 1004
-----------	-----------

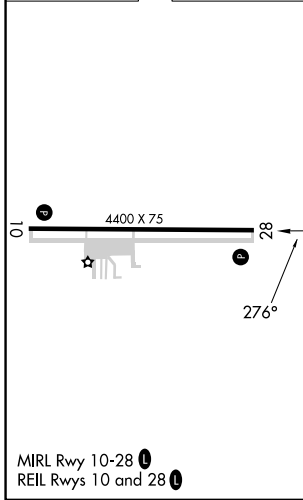

MIRL Rwy 10-28 1
REIL Rwys 10 and 28 1

Procedure NA for arrivals at GAREN on V8 eastbound.

3000	HIATT	BAGEL	tr 286°	△	VGSI and RNAV glidepath not coincident (VGSI Angle 3.50/TCH 31).
↑	✧				4 NM Holding Pattern
CATEGORY	A	B	C	D	
LPV DA	1352-1 1/8	348 (400-1 1/8)			NA
LNAV/VNAV DA	1276-1	272 (300-1)			NA
LNAV MDA	1520-1	516 (600-1)			NA
CIRCLING	1600-1	596 (600-1)			NA

KENDALLVILLE, INDIANA
Amdt 1B 24MAY18

41°28'N-85°16'W

RNAV (GPS) RWY 28

EC-2, 11 JUL 2024 to 08 AUG 2024

EC-2, 11 JUL 2024 to 08 AUG 2024