

| | | | |
|--|------------------------|-----------------------------|---|
| WAAS CH 86637 W27A | APP CRS 269° | Rwy Idg TDZE Apt Elev | 3098 465 465 |
|--|------------------------|-----------------------------|---|

RNAV (GPS) RWY 27

BRANDYWINE RGNL (OQN)

| | | | |
|---|--|--|--|
| RNP APCH - GPS. | | MISSED APPROACH: Climb to 1500 then climbing right turn to 2900 direct GONVE and hold. | |
| <p>⚠ Rwy 27 helicopter visibility reduction below 3/4 SM NA. When local altimeter setting not received, use Coatesville altimeter setting and increase all MDAs 60 feet.</p> | | | |

| | | | |
|-------------------------|--|--------------------------|---------------------------------|
| AWOS-3T 121.4 | PHILADELPHIA APP CON 124.35 319.15 | CLNC DEL 125.6 | UNICOM 123.075 (CTAF) |
|-------------------------|--|--------------------------|---------------------------------|

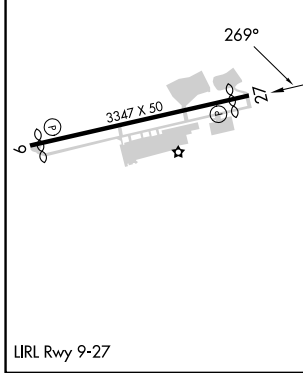
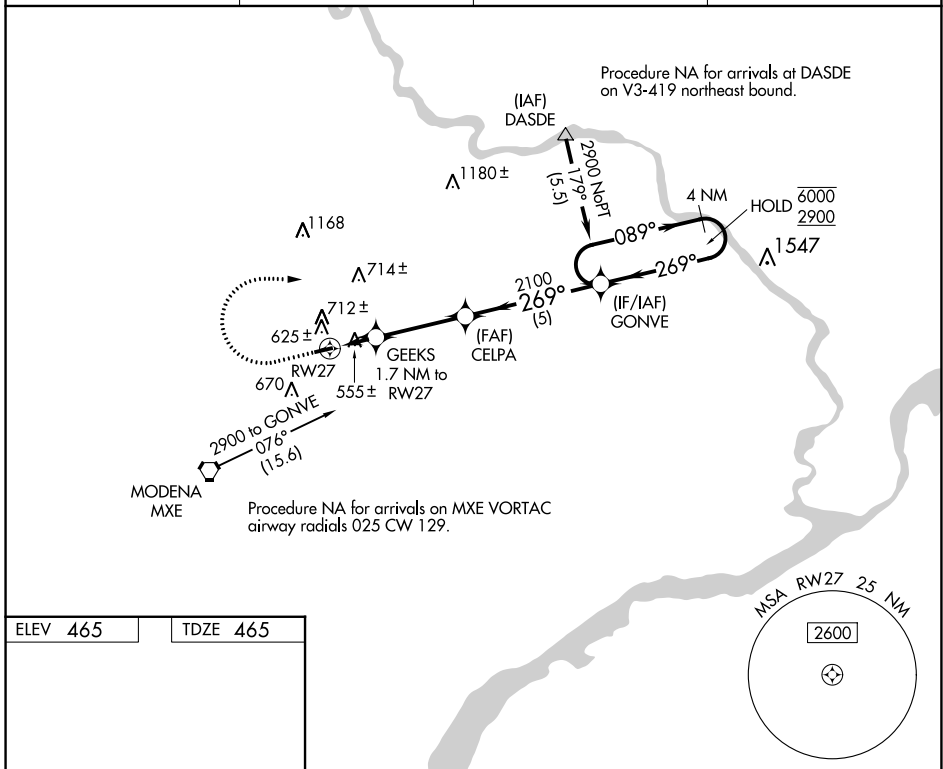

| | | | | |
|--|--------|-----------------------------------|--|----|
| 1500 | 2900 | GONVE | VGSI and descent angles not coincident (VGSI Angle 3.00/TCH 20). | |
| | | | | |
| | | | | |
| <p>GONVE 4 NM Holding Pattern</p> | | <p>GONVE 4 NM Holding Pattern</p> | | |
| <p>RW27 1.1 NM to RW27</p> | | <p>GEEKS 1.7 NM to RW27</p> | | |
| <p>1.1 NM to RW27</p> | | <p>CELPA</p> | | |
| <p>1040</p> | | <p>2100</p> | | |
| <p>3.00° TCH 45</p> | | <p>269°</p> | | |
| <p>089°</p> | | <p>269°</p> | | |
| <p>6000</p> | | <p>2900</p> | | |
| <p>1.1 NM</p> | | <p>0.6 NM</p> | | |
| <p>3.3 NM</p> | | <p>5 NM</p> | | |
| CATEGORY | A | B | C | D |
| LP MDA | 820-1 | 355 (400-1) | | NA |
| LNAV MDA | 860-1 | 395 (400-1) | | NA |
| <input checked="" type="checkbox"/> CIRCLING | 1080-1 | 615 (700-1) | | NA |

NE-4, 11 JUL 2024 to 08 AUG 2024

NE-4, 11 JUL 2024 to 08 AUG 2024