

**BIG BEAR CITY** (L35) 0 W UTC-8(-7DT) N34°15.83' W116°51.36'

LOS ANGELES

6752 B TPA—7952(1200) NOTAM FILE RAL

H-4I, L-4H, 7C

RWY 08-26: H5850X75 (ASPH) S-12.5 MIRL

IAP

RWY 08: PAPI(P2L)—GA 4.3° TCH 29'. Thld dspcd 370'. Rgt tfc.

RWY 26: PAPI(P2L)—GA 4.3° TCH 46'. Thld dspcd 600'. Trees.

SERVICE: S2 FUEL 100LL, JET A LGT ACTIVATE MIRL Rwy

08-26—CTAF. PAPI Rwy 08 and PAPI Rwy 26 opr continuously.

NOISE: Extreme noise sensitive area, practice NS ABTMT procedures. NS ABTMT procedures, avoid overflying of high school 1 mile east at all times. On txf make 10° left turn at end of rwy to avoid housing to east and elementary school to west of arpt.

AIRPORT REMARKS: Attended 1600-0100Z†. Jet A fuel avbl 1600-0000Z†, self svc after hrs. 100LL avbl 24 hr self svc. Mountains all quadrants, peak haz lgts SE, S, & NW.

AIRPORT MANAGER: 909-585-3219

WEATHER DATA SOURCES: AWOS-3 135.925 (909) 585-4033.

COMMUNICATIONS: CTAF/UNICOM 122.725

Ⓡ L.A. CENTER APP/DEP CON 126.35

CLEARANCE DELIVERY PHONE: For CD ctc Los Angeles ARTCC at 661-575-2079.

RADIO AIDS TO NAVIGATION: NOTAM FILE RAL.

PARADISE (VH) (H) VORTACW 112.2 PDZ Chan 59 N33°55.10' W117°31.80' 043° 39.4 NM to fld. 1432/15E.

TACAN AZIMUTH unusable:

130°-145° byd 25 NM blo 5,000'

145°-190° blo 8,000'

190°-230° blo 10,000'

310°-325° byd 35 NM blo 10,900'

325°-345° byd 25 NM blo 11,500'

345°-360° byd 35 NM blo 10,500'

VOR unusable:

000°-006° byd 40 NM

007°-017° byd 40 NM blo 10,000'

007°-017° byd 48 NM

010°-015° byd 20 NM blo 10,000'

018°-040° byd 40 NM

041°-051° byd 40 NM blo 25,000'

052°-065° byd 40 NM

080°-088° byd 40 NM

108°-118° byd 40 NM blo 9,000'

108°-118° byd 53 NM

119°-144° byd 40 NM blo 12,000'

119°-144° byd 85 NM

130°-145° byd 25 NM blo 5,000'

145°-190° blo 8,000'

145°-190° byd 25 NM blo 10,000'

145°-190° byd 39 NM blo 13,500'

190°-230° blo 10,000'

285°-300° byd 40 NM

301°-311° byd 40 NM blo 18,000'

310°-325° byd 35 NM blo 10,900'

325°-345° byd 25 NM blo 11,500'

345°-360° byd 35 NM blo 10,500'

DME unusable:

130°-145° byd 25 NM blo 5,000'

145°-190° blo 8,000'

190°-230° blo 10,000'

310°-325° byd 35 NM blo 10,900'

325°-345° byd 25 NM blo 11,500'

345°-360° byd 35 NM blo 10,500'

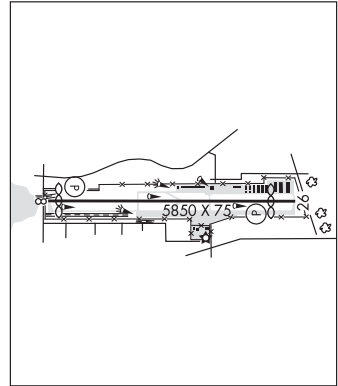

**BIG SUR** N36°10.88' W121°38.53' NOTAM FILE OAK.

SAN FRANCISCO

(L) (L) VORTACW 114.0 BSR Chan 87 104° 22.7 NM to Tusi AHP (Hunter Liggett). 4080/16E.

H-4H, L-3C

DME portion unusable:

320°-085° byd 35 NM blo 9,000'

RCO 122.2 (OAKLAND RADIO)