

MIDWAY SEVEN DEPARTURE

AL-81 (FAA)

CHICAGO MIDWAY INTL (MDW)
CHICAGO, ILLINOIS

D-ATIS 132.75
 CLNC DEL
 124.625
 CPDLC
 GND CON
 118.075
 MIDWAY TOWER
 135.2 269.125
 CHICAGO DEP CON
 128.2 353.875

RNAV 1 - GPS from ACITO, BACEN, CMSKY,
 DENNT, EARND, LEWKE, PEKUE, PMPKN, RAYNR.

RADAR required.

**TOP ALTITUDE:
 3000**

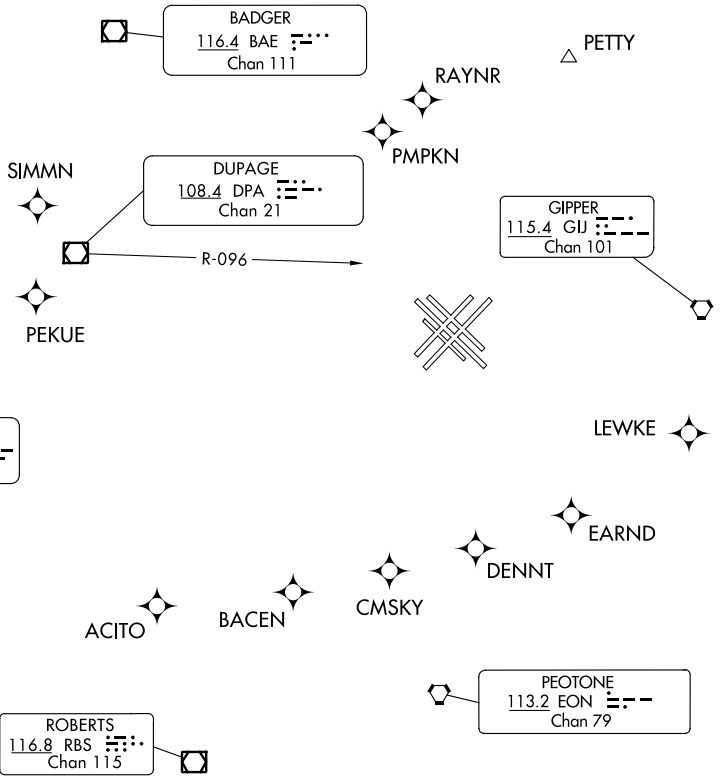
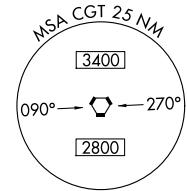

NOTE: All Turbo-Jet departures, in all directions, accelerate to 250K immediately upon entering or outside the lateral confines of ORD Class B airspace, then maintain 250K until advised by ATC.

TAKEOFF MINIMUMS:

Rwy 4L/R, 13L/C, 22L/R, 31C/R: Standard.

NOTE: Chart not to scale.

DEPARTURE ROUTE DESCRIPTION

ALL AIRCRAFT:
 TAKEOFF RUNWAYS 4L/R, 13L/C, 22L/R, 31C/R: Climb on assigned heading for RADAR vectors to filed/assigned route or depicted fix. Maintain 3000, expect filed altitude ten minutes after departure.

ALL AIRCRAFT: Complete initially assigned turn within 4 NM of KMDW airport.

MIDWAY SEVEN DEPARTURE