

**TUSI AHP (HUNTER LIGGETT) HELIPORT** (HGT)(KHGT) A 3 NW UTC-8(-7DT) N35°59.61' W121°14.20' **LOS ANGELES**  
 1017 B NOTAM FILE OAK Not insp. **L-3C**  
**HELIPAD 14-32:** H570X50 (CONC) MIRL **DIAP**  
**SERVICE:** **MILITARY— FUEL** Avbl 1600-0000Z± Mon-Fri exc hol. PPR DSN 686-2403/2503. J8.  
**NOISE:** Procedure (remain 1000' AGL) in effect outside of Ft. Hunter Liggett boundary. Acft remain clear of cantonment area, lakes and reservoirs.  
**MILITARY REMARKS:** RSTD CLOSED to fixed wing acft. 24 hr PPR all acft. Ctc Range Con DSN 686-2403/2503, C831-386-2403/2503 for entry approval of Hunter Liggett Reservation. **CAUTION** Parking ramp/twy less than minimum clearance, exercise extreme caution, acft parked within 150' of centerline. **MISC** Tactical fixed wing airstrip (Schoonover Landing Zone) avbl for C-130 and OV-10 mil fixed wing acft only, 2 1/4 NM SE of main heliport. Fuel unavbl at Schoonover Landing Zone. All acft ctc ops/range cntrl for advsy upon entering reservation on 41.05/126.2/229.5. Ctc arpt advsy on 38.8/241.0.  
**COMMUNICATIONS:** (R) **OAKLAND CENTER APP/DEP CON** 128.7 307.0  
**CLEARANCE DELIVERY PHONE:** For CD ctc Oakland ARTCC at 510-745-3380.  
**RADIO AIDS TO NAVIGATION:** NOTAM FILE OAK.  
**BIG SUR (L) VORTACW** 114.0 BSR Chan 87 N36°10.88' W121°38.53' 104° 22.7 NM to fld. 4080/16E.  
 DME portion unusable:  
 320°-085° byd 35 NM blo 9,000'

**TWENTYNINE PALMS** (TNP)(KTNP) 6 E UTC-8(-7DT) N34°07.90' W115°56.75' **LOS ANGELES**  
 1888 B NOTAM FILE RAL MON Airport **H-4I, L-4I**  
**RWY 08-26:** H5531X75 (ASPH) MIRL 1.6% up W **IAP, DIAP**  
**RWY 08:** REIL. PAPI(P2L)—GA 3.0° TCH 40'. P-line.  
**RWY 26:** REIL. PAPI(P2L)—GA 3.0° TCH 40'.  
**RWY 17-35:** H3797X50 (ASPH) MIRL 0.9% up S  
**RWY 17:** P-line.  
**RWY 35:** Hill.  
**SERVICE:** S2 **FUEL** 100LL **LGT** ACTIVATE MIRL Rwy 08-26 and Rwy 17-35, REIL Rwy 08 and 26—CTAF. Twy lgts on twy connecting Rwy 08-26 and Rwy 17-35, plus blue reflectors on parallel twy serving Rwy 17-35.  
**AIRPORT REMARKS:** Unattended. Be alert for acrobatic activity south of Rwy 17-35. 100LL fuel avbl 24 hrs.  
**AIRPORT MANAGER:** 909-387-8810  
**COMMUNICATIONS:** CTAF/AUNICOM 122.8  
**RCO** 122.1R 114.2T (RIVERSIDE RADIO)  
 (R) **L.A. CENTER APP/DEP CON** 128.15  
**CLEARANCE DELIVERY PHONE:** For CD if una to ctc on FSS freq, ctc Los Angeles ARTCC at 661-575-2079.

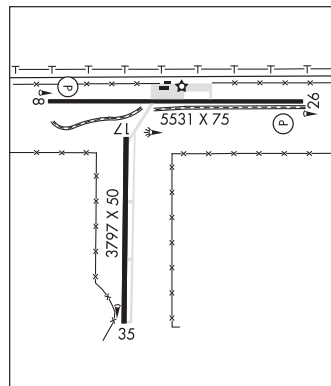

CONTINUED ON NEXT PAGE

## CONTINUED FROM PRECEDING PAGE

## RADIO AIDS TO NAVIGATION: NOTAM FILE RAL.

(L) (L) VORTAC 114.2 TNP Chan 89 N34°06.73' W115°46.19' 263° 8.8 NM to fld. 1374/15E.

## VOR unusable:

005°-035° byd 18 NM blo 6,800'  
 035°-065° byd 25 NM blo 6,000'  
 080°-095° byd 30 NM blo 6,000'  
 095°-150° byd 18 NM blo 6,000'  
 151°-170° byd 20 NM blo 7,000'  
 170°-190° byd 25 NM blo 9,000'  
 190°-245° byd 20 NM blo 7,000'  
 245°-260° byd 25 NM blo 7,500'  
 315°-330° byd 33 NM blo 6,200'  
 330°-345° byd 20 NM blo 6,200'  
 345°-005° byd 35 NM blo 8,300'

## TAC AZM unusable:

005°-035° byd 18 NM blo 6,800'  
 035°-065° byd 25 NM blo 6,000'  
 080°-095° byd 30 NM blo 6,000'  
 095°-150° byd 18 NM blo 6,000'  
 150°-170° byd 20 NM blo 7,000'  
 170°-190° byd 25 NM blo 9,000'  
 190°-205° byd 20 NM blo 7,000'  
 205°-265°  
 315°-330° byd 33 NM blo 6,200'  
 330°-345° byd 20 NM blo 6,200'  
 345°-005° byd 35 NM blo 8,300'

## DME unusable:

005°-035° byd 18 NM blo 6,800'  
 035°-065° byd 25 NM blo 6,000'  
 080°-095° byd 30 NM blo 6,000'  
 095°-150° byd 18 NM blo 6,000'  
 150°-170° byd 20 NM blo 7,000'  
 170°-190° byd 25 NM blo 9,000'  
 190°-245° byd 20 NM blo 7,000'  
 245°-260° byd 25 NM blo 7,500'  
 315°-330° byd 33 NM blo 6,200'  
 330°-345° byd 20 NM blo 6,200'  
 345°-005° byd 35 NM blo 8,300'

---