

WAAS CH 65918 W31A	APP CRS 307°	Rwy Idg TDZE Apt Elev	4201 1394 1402
--	------------------------	-----------------------------	---

RNAV (GPS) RWY 31

BARNES COUNTY MUNI (BAC)

RNP APCH - GPS.

⚠ Baro-VNAV NA when using Jamestown altimeter setting. For uncompensated Baro-VNAV systems, LNAV/VNAV NA below -17°C or above 54°C. When local altimeter setting not received, use Jamestown altimeter setting: increase LPV DA to 1721 feet and all visibilities ¾ SM; increase LNAV/VNAV DA to 1794 and all visibilities ¾ SM; increase all MDA 80 feet and visibility Circling Cat C ¼ SM. Circling NA to Rwy 5, 8, 17, 23, 26, and 35. Rwy 31 helicopter visibility reduction below ¾ SM NA.

MISSED APPROACH: Climb to 3000 direct CISGI and hold.

AWOS-3 118.725	MINNEAPOLIS CENTER 124.2 270.3	UNICOM 122.8 (CTAF) 📻
--------------------------	--	--

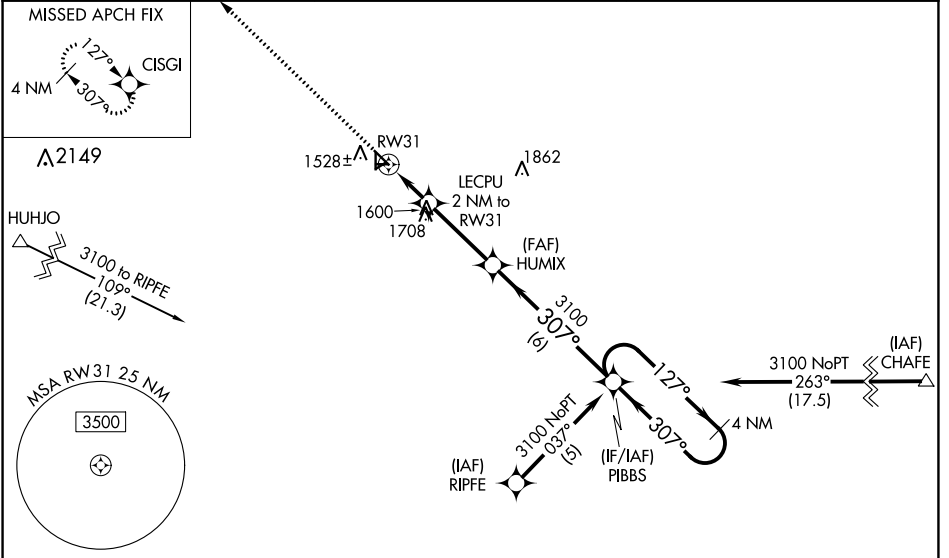

ELEV 1402	TDZE 1394
------------------	------------------

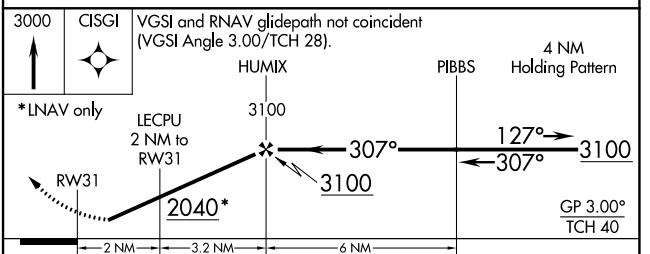
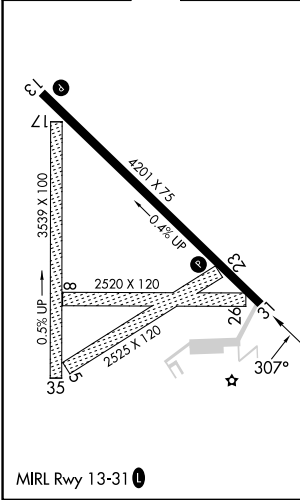

CATEGORY	A	B	C	D
LPV DA	1644-1		250 (300-1)	NA
LNAV/VNAV DA	1717-1¼		323 (400-1¼)	NA
LNAV MDA	1900-1	506 (500-1)	1900-1½ 506 (500-1½)	NA
CIRCLING	1920-1 518 (600-1)	2000-1 598 (600-1)	2020-1¾ 618 (700-1¾)	NA

NC-1, 31 OCT 2024 to 28 NOV 2024

NC-1, 31 OCT 2024 to 28 NOV 2024