

LOC I-CSV 109.1	APP CRS 255°	Rwy ldg TDZE Apt Elev	5423 1871 1882
---------------------------	------------------------	-----------------------------	---

ILS Z or LOC Z RWY 26

CROSSVILLE MEML-WHITSON FLD (CSV)

⚠ Autopilot coupled approach NA below 2500. Procedure NA at night. Rwy 26 helicopter visibility reduction below 1 SM NA.

⚠ MISSED APPROACH: Climb to 3000 then climbing left turn to 5000 on heading 180° and HCH VOR/DME R-303 to HCH VOR/DME and hold.

ASOS 120.625	ATLANTA CENTER 133.6 254.3	UNICOM 122.7 (CTAF) 0
------------------------	--------------------------------------	---------------------------------

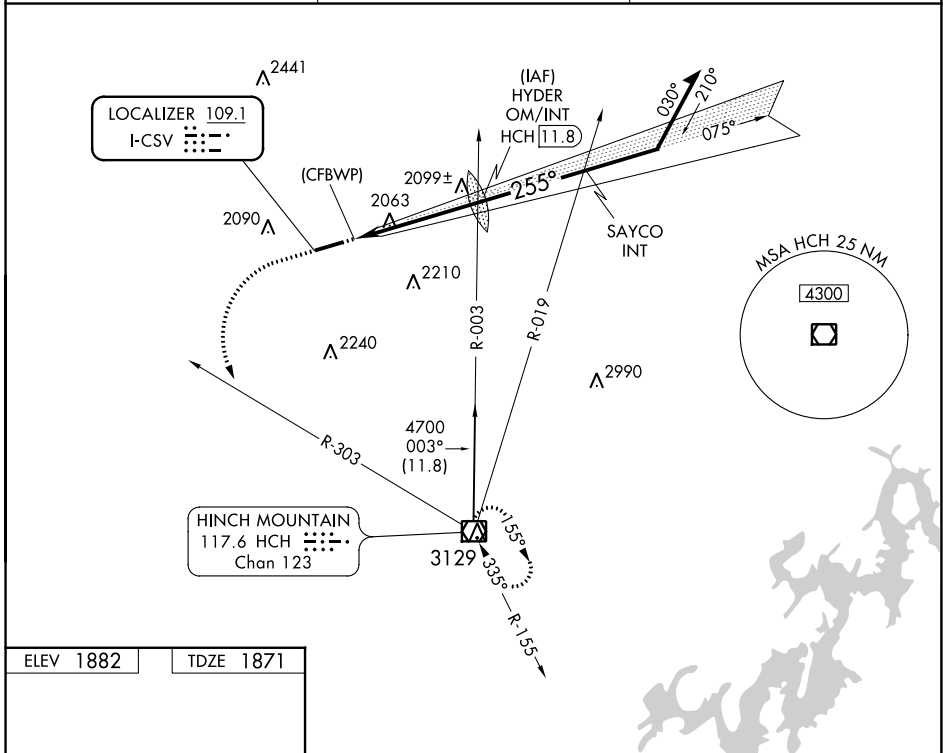

ELEV 1882	TDZE 1871
-----------	-----------

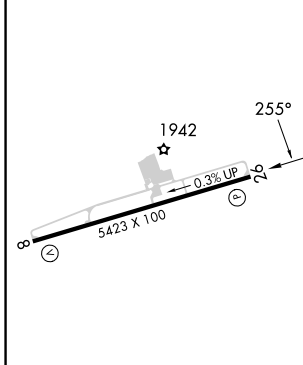

REIL Rwy 26	HIRL Rwy 8-26 0				
FAF to MAP 4.7 NM					
Knots	60	90	120	150	180
Min:Sec	4:42	3:08	2:21	1:53	1:34

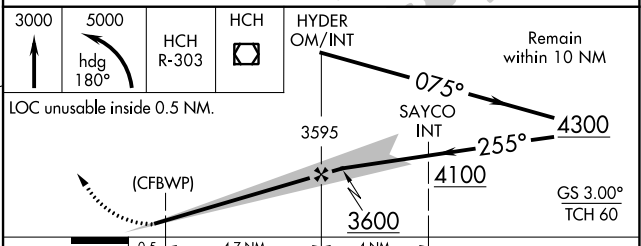

CATEGORY	A	B	C	D
S-ILS 26	2121-1 250 (300-1)			
S-LOC 26	2440-1	569 (600-1)	2440-1½	569 (600-1½)
0 CIRCLING	2440-1	558 (600-1)	2440-1½	2540-2 658 (700-2)