

JENA (1R1) 2 SW UTC-6(-5DT) N31°40.13' W92°09.46'

216 B NOTAM FILE DRI

RWY 18-36: H4901X75 (ASPH) S-12 MIRL

RWY 18: REIL. PAPI(P2L)—GA 3.0° TCH 50'. Thld dspcd 1101'. Trees.

RWY 36: REIL. PAPI(P2L)—GA 3.0° TCH 50'. Trees.

SERVICE: LGT Dusk-Dawn. MIRL Rwy 18-36 and REIL Rwy 18 and 36 preset low instst dusk-dawn, to incr instst ACTVT—CTAF. Rwy 36 REIL OTS. Rwy 36 PAPI OTS.

AIRPORT REMARKS: Unattended.

AIRPORT MANAGER: 318-312-1200

COMMUNICATIONS: CTAF 122.9

CLEARANCE DELIVERY PHONE: For CD ctc Polk Apch at 337-531-2352.

RADIO AIDS TO NAVIGATION: NOTAM FILE AEX.

ALEXANDRIA (H) (H) VORTACW 116.1 AEX Chan 108 N31°15.40' W92°30.06' 032° 30.3 NM to fld. 76/3E.

VOR unusable:

035°-065° blo 2,000'

066°-094° byd 35 NM blo 3,000'

185°-200° byd 35 NM blo 3,000'

201°-214° byd 35 NM blo 2,000'

215°-260° blo 2,000'

261°-285° byd 35 NM blo 2,000'

357°-034° byd 35 NM blo 3,000'

HOUSTON

L-22E

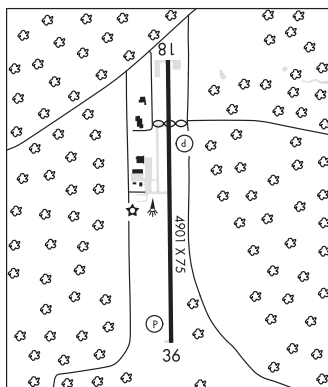

JENNINGS (3R7) 1 NW UTC-6(-5DT) N30°14.56' W92°40.41'

23 B NOTAM FILE DRI

RWY 08-26: H5002X75 (ASPH) S-12 MIRL

RWY 08: REIL. PAPI(P2L)—GA 3.0° TCH 50'. Trees.

RWY 26: REIL. PAPI(P2L)—GA 3.0° TCH 50'. Pole. Rgt tfc.

RWY 13-31: H3601X75 (ASPH) S-12 MIRL

RWY 13: REIL. PAPI(P2L)—GA 3.0° TCH 50'. Sign. Rgt tfc.

RWY 31: REIL. PAPI(P2L)—GA 3.0° TCH 50'. Thld dspcd 588'. Bldg.

RWY 17-35: 1977X150 (TURF)

RWY 17: Pole. Rgt tfc.

RWY 35: P-line.

SERVICE: FUEL 100LL, JET A LGT Actvt MIRL Rwy 08-26, Rwy 13-31—CTAF.

AIRPORT REMARKS: Attended Mon-Fri 1200-2200Z†. Ultralight activity invof arpt. Numerous agricultural acct invof arpt. Self svc fuel avbl after hrs with credit card. Rwy 17-35 and thld outlined with orange cones. 20' unlgtd tower 150' from approach end Rwy 35. NOTE: See Special Notices—Aerobatic Practice Area.

AIRPORT MANAGER: 337-616-2370

WEATHER DATA SOURCES: AWOS-3PT 121.150 (337) 824-0517.

COMMUNICATIONS: CTAF/UNICOM 122.8

Ⓡ LAKE CHARLES APP/DEP CON 119.8 (1200-0400Z‡)

Ⓡ HOUSTON CENTER APP/DEP CON 124.7 (0400-1200Z‡)

CLEARANCE DELIVERY PHONE: For CD ctc Houston ARTCC at 281-230-5622.

RADIO AIDS TO NAVIGATION: NOTAM FILE LCH.

LAKE CHARLES (H) (H) VORTACW 113.4 LCH Chan 81 N30°08.49' W93°06.33' 068° 23.3 NM to fld. 20/7E.

VOR unusable:

181°-359° byd 30 NM blo 1,500'

HOUSTON

H-7D, L-21B, 22E, GOMW

IAP

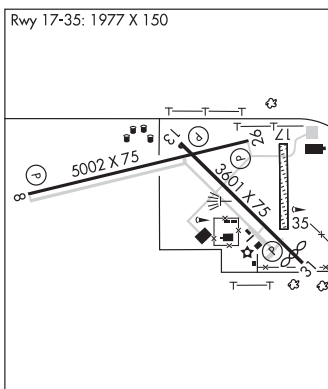

JOHN H HOOKS JR MEML (See RAYVILLE on page 123)