

VOR/DME BSV 114.05 Chan 87 (Y)	APP CRS 182°	Rwy Idg TDZE Apt Elev 894	N/A N/A 894
--	------------------------	---	--

VOR-A

HARRY CLEVER FLD (PHD)

DME or RADAR required.		MISSED APPROACH: Climb to 2100 then climbing left turn to 3000 direct BSV VOR/DME and hold.
▽ Circling NA to Rwys 12 and 30. Rwy 15, 33 helicopter visibility reduction below 1 SM	⚠ NA. Procedure NA at night.	

ASOS 121.425	CLEVELAND APP CON* 125.5 371.875	UNICOM 122.8 (CTAF)	123.3 0
------------------------	--	-------------------------------	----------------

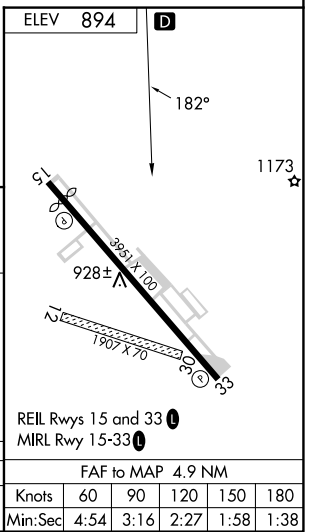
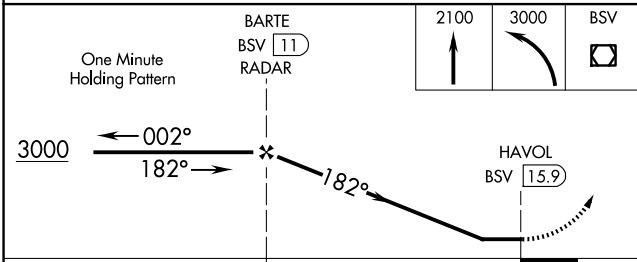
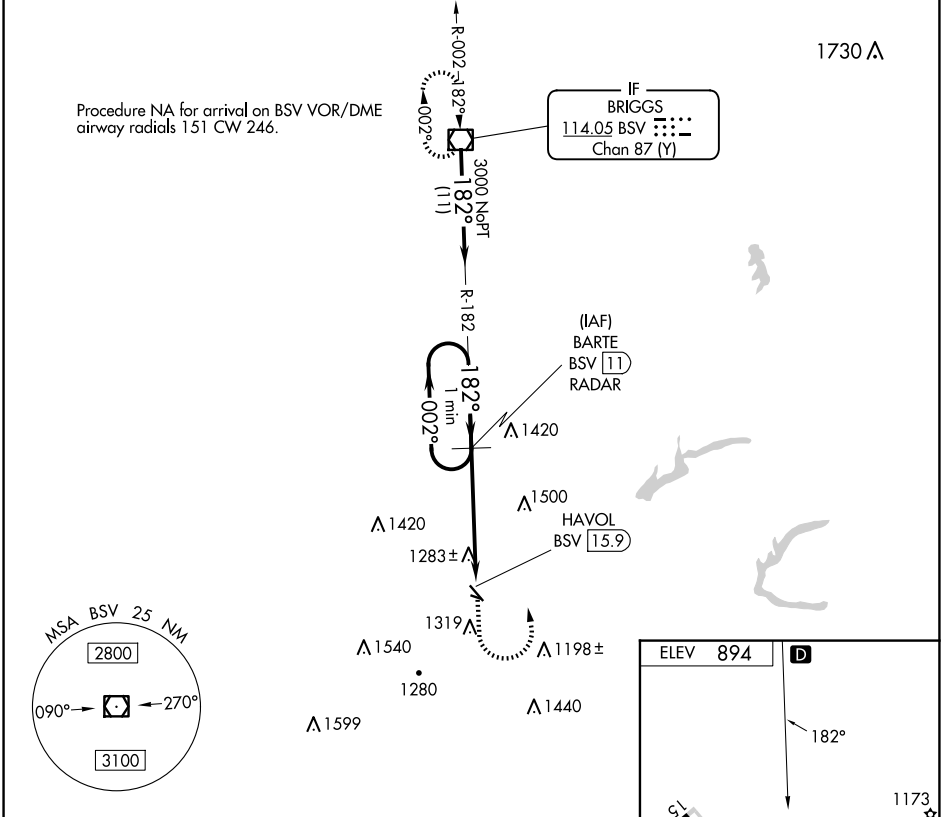

CATEGORY	A	B	C	D	FAF to MAP 4.9 NM						
ⓐ CIRCLING	1720-1¼	826 (900-1¼)	1720-2½	826 (900-2½)	NA	Knots	60	90	120	150	180
						Min:Sec	4:54	3:16	2:27	1:58	1:38

VOR-A

EC-2, 23 JAN 2025 to 20 FEB 2025

EC-2, 23 JAN 2025 to 20 FEB 2025