

# CCOBB THREE DEPARTURE (RNAV)

EC-1, 20 MAR 2025 to 17 APR 2025

DETROIT DEP CON  
 125.525 284.0 (Rwy 3L/R, 4L/R, 21L/R, 22L/R)  
 132.025 284.0 (Rwy 27L/R)  
 D-ATIS 118.125  
 CLNC DEL 120.65  
 CPDIC  
 GND CON  
 121.8 (NW) 119.45 (NE)  
 132.725 (SW) 119.25 (SE)  
 METRO TOWER  
 118.4 317.725 (Rwys 3L/R, 21L/R, 27R)  
 128.75 317.725 (Rwy 27L)  
 135.0 317.725 (Rwy 4L/R, 22L/R)

RNAV 1 - DME/DME/IRU or GPS.  
 RADAR required.

**TOP ALTITUDE:  
 17000**

ZEGBI  
 9000  
 \*2500  
 278° (31)

CCOBB

BROZZ

FDRCH  
 279° (10)

262° (2A)

AVERL  
 7000

FERRM  
 259° (7)

NIITRN  
 2500 230K  
 304° (5)

NAPOLEON

TAKEOFF MINIMUMS:  
 Rwys 27L/R: Standard.  
 Rwys 3L/R, 4L/R, 21L/21R, 22L/R: Standard with  
 minimum climb of 500'/NM to 1146.

NOTE: Turbojet departures at/above 10000, maintain 280K until advised by ATC.  
 NOTE: For use by aircraft filed at or below FL220, or as assigned by ATC.  
 NOTE: CAUTION; Parachute jumping 6 NM SW of BROZZ.  
 3 NM radius of Napoleon Airport (3NP) at or below 17999 (SR-SS).

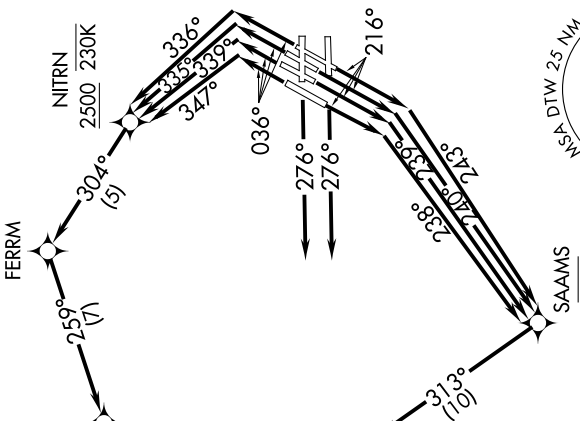

(CONTINUED ON FOLLOWING PAGE)

NOTE: Chart not to scale.

# CCOBB THREE DEPARTURE (RNAV)

EC-1, 20 MAR 2025 to 17 APR 2025