

|                                   |                        |                             |   |
|-----------------------------------|------------------------|-----------------------------|---|
| LOC I- <b>PKX</b><br><b>108.3</b> | APP CRS<br><b>356°</b> | Rwy ldg<br>TDZE<br>Apt Elev | <b>4097</b><br><b>1086</b><br><b>1096</b> |
|-----------------------------------|------------------------|-----------------------------|---|

**LOC RWY 36**  
JOHNSON COUNTY EXEC (OJC)

|  |                       |   |  |                         |
|--|-----------------------|---|--|-------------------------|
| NA<br>Helicopter visibility reduction below 3/4 SM not authorized. For inoperative MALSRS, increase S-36 Cats A and B visibility 1/4 mile. | MALSRS<br>            |   | MISSED APPROACH: Climb to 1700 then climbing right turn to 2700 direct HERBB LOM and hold. |                         |
|  | ATIS<br><b>119.35</b> | KANSAS CITY APP CON<br><b>118.9 251.075</b> | EXECUTIVE TOWER*<br><b>126.0 (CTAF) 225.4</b>  | GND CON<br><b>121.6</b> |

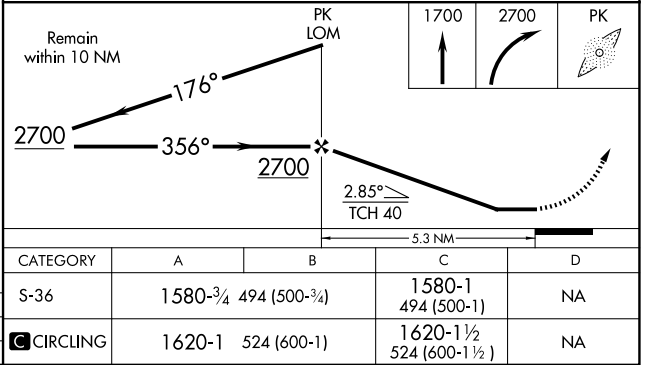
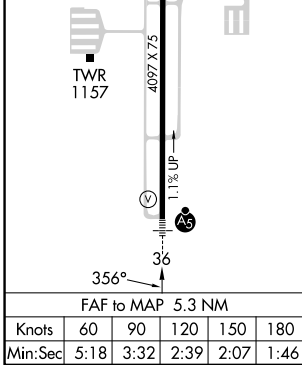
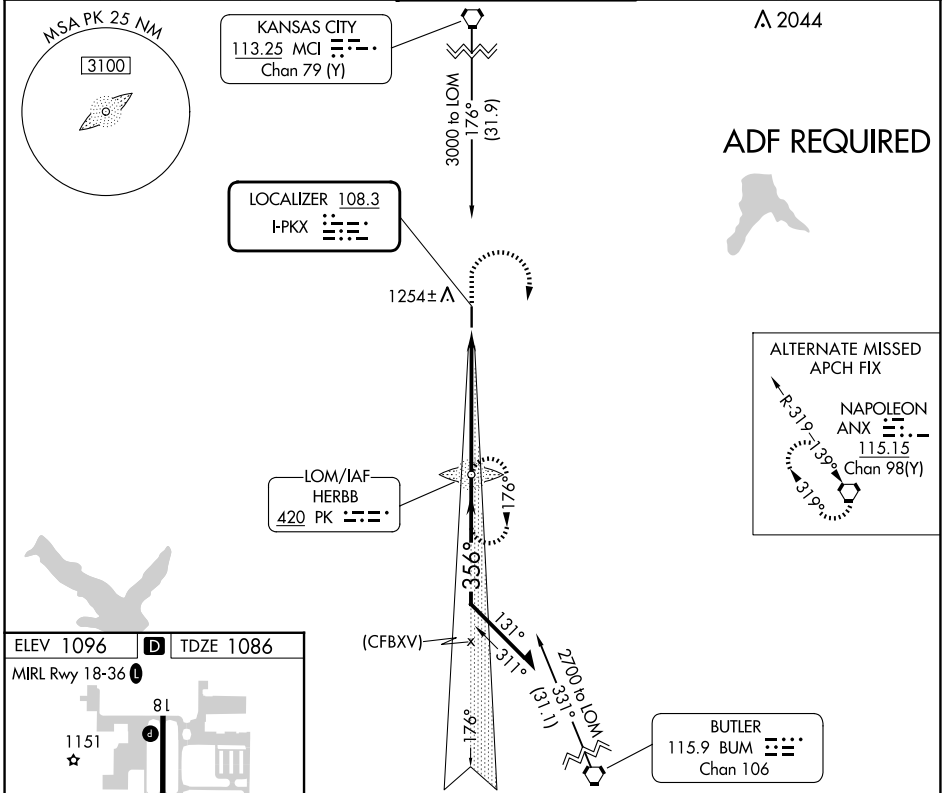

NC-2, 20 MAR 2025 to 17 APR 2025

NC-2, 20 MAR 2025 to 17 APR 2025