

WAAS CH <b>82441</b> <b>W29A</b>	APP CRS <b>291°</b>	Rwy Idg TDZE Apt Elev	<b>3200</b> <b>29</b> <b>29</b>
--	------------------------	-----------------------------	---------------------------------------

# RNAV (GPS) RWY 29

BUCKLAND (BVK)(PABL)

RNP APCH.  
 ▼ Rwy 29 helicopter visibility reduction below 3/4 SM NA. VDP NA when using Selawik altimeter setting. When Buckland altimeter setting not received, use Selawik altimeter setting and increase all MDA 120 feet, LNAV Cat C visibility 3/8 SM and Circling Cat C 1/4 SM.

MISSED APPROACH:  
 Climb to 2900 direct HAGVA and hold.

AWOS-3P <b>135.15</b>	ANCHORAGE CENTER <b>119.2 263.0</b>	KOTZEBUE RADIO <b>122.3</b>	CTAF <b>122.9</b>
--------------------------	--	--------------------------------	----------------------

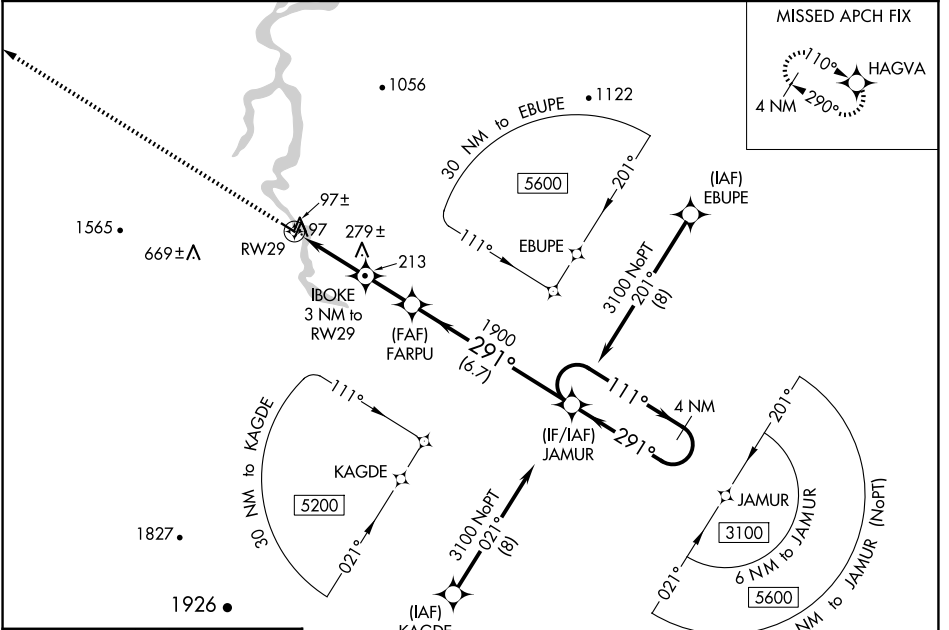

ELEV 29	TDZE 29
---------	---------

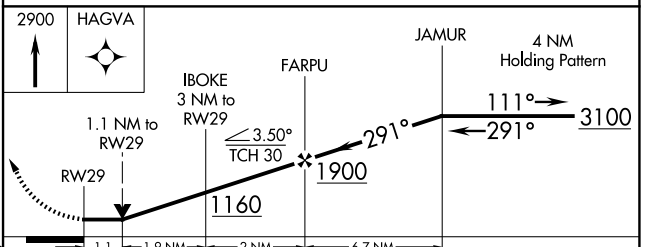
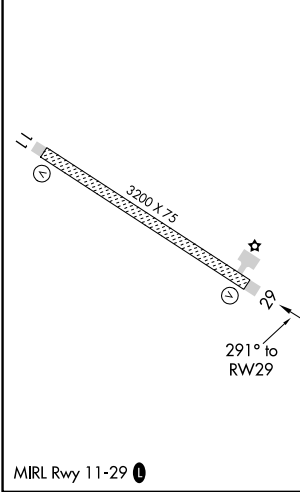

CATEGORY	A	B	C	D
LP MDA	480-1 451 (500-1)			NA
LNAV MDA	540-1	511 (600-1)	540-1 3/8 511 (600-1 3/8)	NA
<input checked="" type="checkbox"/> CIRCLING	540-1	511 (600-1)	640-1 3/4 611 (700-1 3/4)	NA

AK, 20 FEB 2025 to 17 APR 2025

AK, 20 FEB 2025 to 17 APR 2025